

FMP-901-N or P
 Single Rack Gas Baking Oven
 FMP Equipment Corp.
 Greensboro, NC 27415
 336-621-2882

Key

- 1 - Hood Exhaust 8.00 Diameter
- 2 - 3 Ph. Electric Service
 240/480 Volt*
 10/5 Amp*
 *240V **OR** 480V to be specified upon order entry
 60 Hz.
- 3 - 1 Ph. Electric Service
 120 Volt, 60 Hz
 20 Amp dedicated circuit
 Oven Control: 3 Amp (Clean Power)
 Ventilator connect point: 10 Amp, 1/3 HP
- 4 - Water Service 1/4" NPT
 Cold Water @ 45 PSI min. @ 4.5 GPM flow rate
- 5 - Choose lower left or rear corner drain.
 Route to air gap drain
- 6 - Powered Hood Exhaust W / Downdraft Preventive Cap
 750 CFM Req'd. (.5" w.c. static pressure drop through hood)
 Customer to supply duct and ventilator fan per local code. Consult local authorities to determine whether TYPE I (meats) or TYPE II (no grease) duct and ventilator fan will be required. Products of combustion and chamber vents are factory ducted to this integral hood. Airflow proving switch is factory installed.
- 7 - 1/2" NPT Gas Service
 125,000 BTU/Hr
- 8 - Weight Approximately 1550 Lbs.

CAUTION:

- Use **ONLY** on specially constructed noncombustible floors. See Installation Instructions
- Exhaust Duct Installation **MUST** be in accordance with NFPA 96 and/or Local Codes.

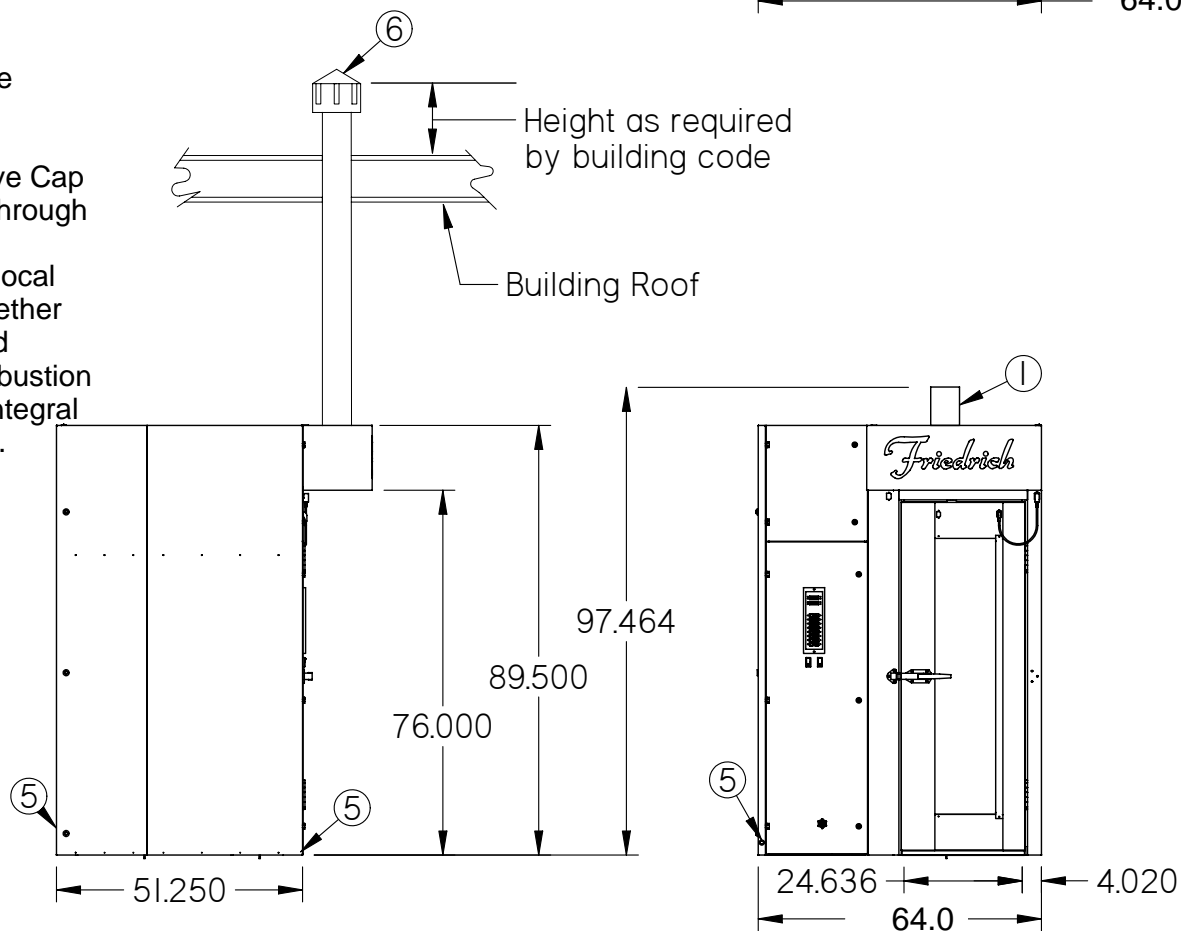
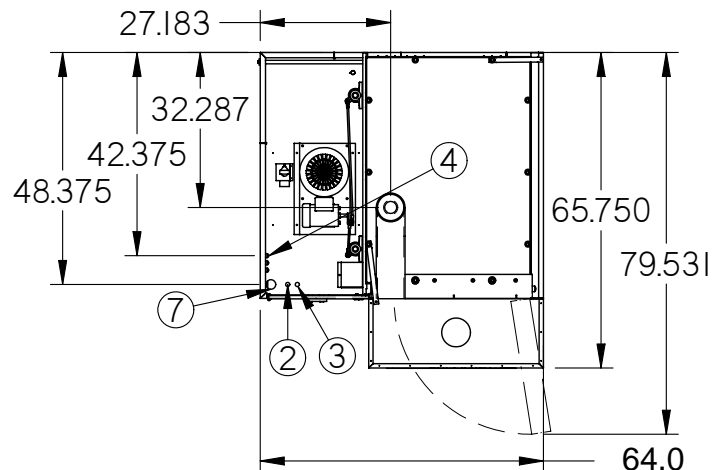

NOTE: Purchaser is responsible for all installation costs and for providing:
 Labor to unload oven upon arrival.
 Installation Mechanics.
 All local service connections including:
 electricity, vents, water & drain per local code.

A FACTORY TECHNICIAN OR FACTORY AUTHORIZED INSTALLATION TECHNICIAN MUST SUPERVISE AND / OR APPROVE ANY INSTALLATION!